



ABOVE AND BEYOND



*Proud to Support First Responders and
Those Serving in Defense of our Nation.*



EAGLEAIR™

BLACKHAWK^{CF}S



Model	CFM* (LPM)	HP	PSIG (BAR)	Weight lbs. (kg)
BHB08S	9.8 (278)	7.5	6000 (414)	2850 (1292.7)
BHB10S	13.3 (377)	10	6000 (414)	2900 (1315.4)

DIMENSIONS: 70"(W) x 37-1/2"(D) x 75"(H) (177.8 cm x 95.3 cm x 190.5 cm)
Weights do not include air storage cylinders.
*Charging rate based on filling an 80 CF cylinder from 0 to 6000 psig.



BLACKHAWKcfs

Breathing Air Cylinder Fill System

Standard & Optional Features

"Top Discharge Extractor" Maintains Ideal Compressor Environment by Removing Heat Generated During the Compression Cycle

Auto Drain Exhaust Air Filter

Integrated System is Designed for Against-the-Wall Installation and Accommodates up to Four (4) Air Storage Cylinders at the Rear of Unit.

Remote Air Intake through Roof.

Priority Fill or Cascade controls with Independent SCBA/SCUBA & Hose Reel valves.

Optional Air Quality Monitoring (CO, H₂O, or Both)

Recessed Cascade Control Panel to Eliminate Accidental Valve Adjustment.

Compact Electrical Control Column with Rotation Feature for Easy Access

"Graphic Technology" Control Panels Logically by Function and Air Flow Direction.

Unique Corner Access Door for All Routine Compressor Services. Simplifies Maintenance & Reduces Downtime.

Unique, Tilt-forward Fill Station Control Panel for Unfettered Maintenance

UL® Certified Two SCBA Containment Design Fill Station, Subjected to Un-Announced Periodic Inspections and Meet NFPA 1901 2016 Edition Rupture Containment Requirements.

Optional Air Reel Package Includes Flow Control Panel & Spring Rewind Reel with 50ft, 75ft, or 100ft Hose Length Options.

Performance-Proven "AirLock" Access Door Design and Balanced Cylinder Fill Enclosure Forward Tilt Rotation Enhances Operator Comfort.

Scratch Resistant, Powder Coated, Seamless Appliance Cabinet with Optional Noise Abatement Insulation.

Integrated / Recessed Casters Allow Fill Station to be Pulled Out for Additional Maintenance Access





BLACKHAWKcfs

Breathing Air Cylinder Fill System

Dimensional Specifications

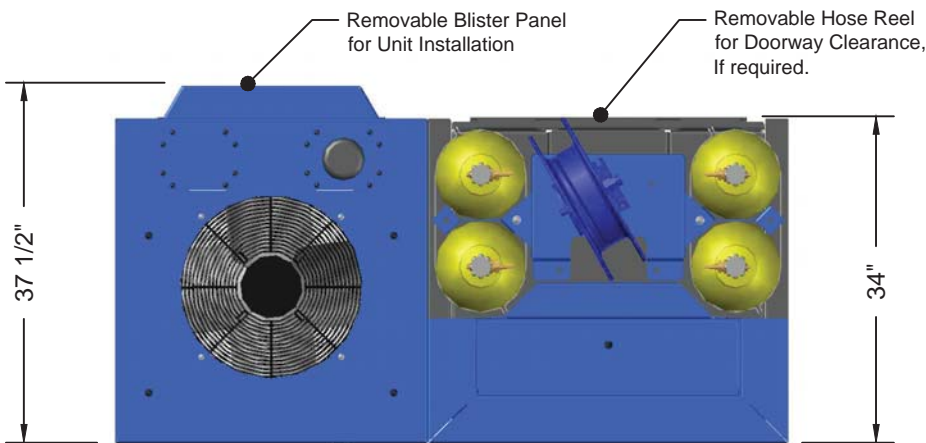

ALLOW 4" FOR REMOTE AIR CONNECTION

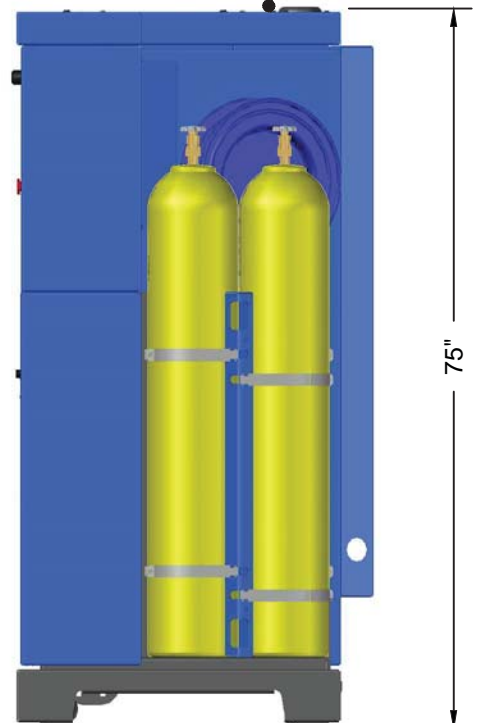



BLACKHAWKcfs

Breathing Air Cylinder Fill System

Dimensional Specifications Open For Maintenance

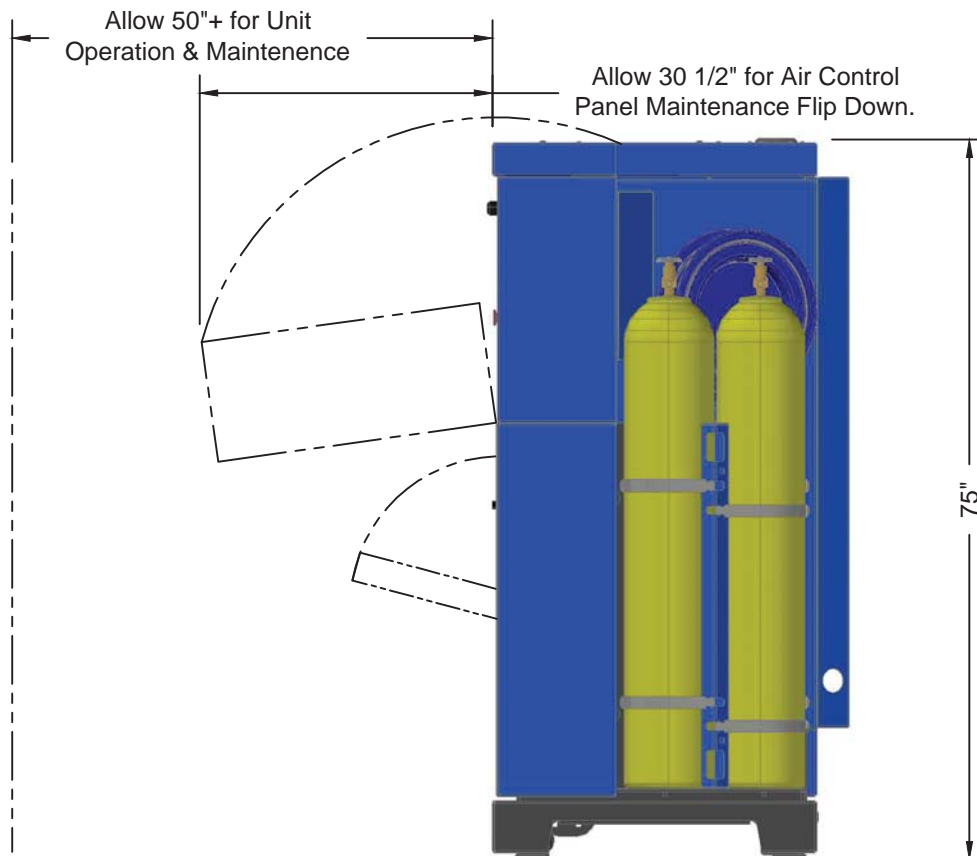
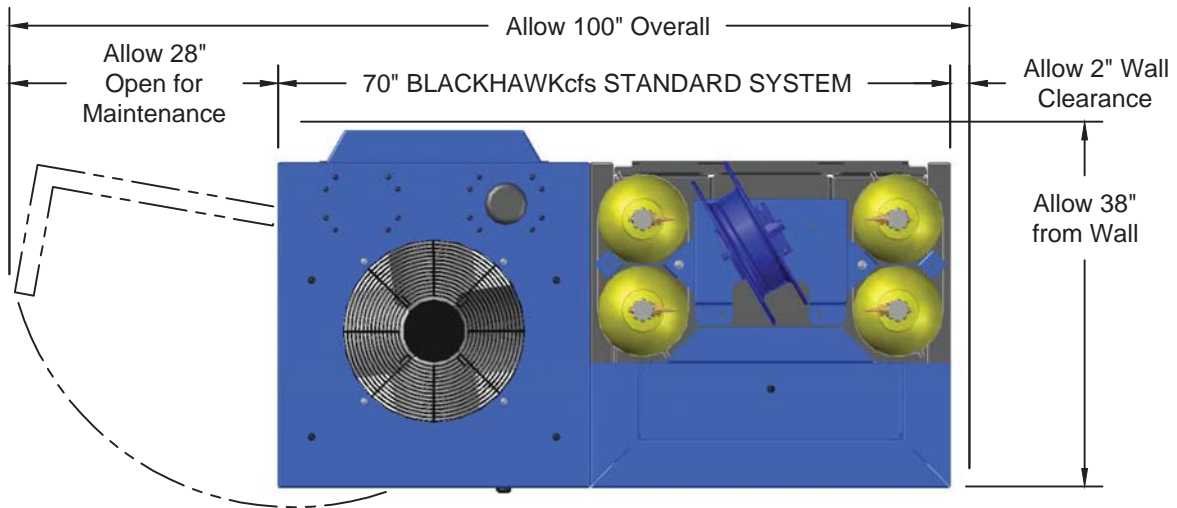

Our Company. Our Commitment.

EagleAir, Inc. is proud of our longstanding commitment to safety and innovation. In business since 1973, the Company has a well known track record of innovations that have become industry standards and have improved firefighter safety. The development of **Containment Design fill stations** and **Single-Appliance breathing air systems** are key examples of these innovations. **For more than 40 years** we have manufactured breathing air systems that **meet and exceed the highest industry standards**. As an American and veteran-owned company, we understand the needs of our armed forces, firefighters, first responders and other customers, and we are dedicated to providing them with the most **advanced, most reliable equipment possible**.

Our commitment starts with an active membership in the **Fire Apparatus Manufacturers Association (FAMA)**. We have also been an active company in **National Fire Protection Association (NFPA)** committees to set standards that assure firefighter safety, so we remain aware and **help drive the latest safety standards**. It continues with a **manufacturing strategy that assures traceability and consistency in all of our products**. And it evolves with a **reputation for continuous improvement** that results in **innovation across all product lines**.

All EagleAir products have unique, technically advanced features that set us apart in the industry

User-Friendly Features



Design Innovation Features



Safety Features & Certifications



EagleAir, Inc. manufactures high pressure breathing air systems for recharging SCBA and SCUBA cylinders. We are proud of the essential service we provide to first responders and those serving in defense of our nation worldwide.

We are committed to a loyalty based national distributor network that includes only top-quality businesses with the necessary assets to serve their regional markets.

Our Company is committed to a continuous improvement philosophy that drives product and service development above and beyond your expectations. Firefighters, commercial and recreational divers, our armed forces, and people who operate in hazardous environments can expect products with uncompromising reliability, best-in-class design and user-friendly features. Our products are backed by a commitment—100% customer service satisfaction.



3003 Thurston Ave., Greensboro, NC 27406
P: (336) 398-8000 F: (336) 398-8001
www.eagleair.com

We would be privileged to assist in selecting the breathing air system that meets your exact needs. Call today.